



ELDOM INVEST Ltd.

Production and trading with household appliances

www.eldominvest.com export@eldominvest.com

**HOUSEHOLD STORAGE
ELECTRICAL WATER HEATERS**
from 30 up to 200 L.
for wall installation

**TECHNICAL DESCRIPTION
MANUAL FOR INSTALLATION, OPERATION AND
MAINTENANCE
IMPORTANT RULES
WARRANTY CONDITIONS**

WARNING! Before installation and operation with the appliance, read carefully the present manual!

TECHNICAL DESCRIPTION

MANUAL FOR INSTALLATION AND OPERATION OF AN ELECTRICAL WATER HEATER FOR DOMESTIC PURPOSES from 30 up to 200 L. (BDS EN 60335-2-21), meant for wall installation (hanging)

Before proceeding with installation and starting up operation with the water heater, it is obligatory to read carefully the present manual. The requirements and recommendations included in it should be strictly observed by you in order to make the operation with the appliance easier, as well as by the qualified persons who will install and eventually repair the appliance in case of a failure. Observance of the rules is a part of the measures for safe operation of the appliance and is also one of the warranty conditions.

ATTENTION! Installation of the water heater and connection to the water main system should be performed only by qualified persons. Installation of safety and other components, provided by the manufacturer, is **OBLIGATORY!**

ATTENTION! Connection of the water heater to electrical installation should be performed only by qualified persons. The appliance should be properly connected to the current-carrying cores, as well as to the protective contour! Do not connect the appliance to the electrical installation before filling its water tank up with water!

WARNING! During operation with the appliance, a risk of burning with hot water exists, if water in the water tank has been heated up to temperatures near the maximum settings of the thermostat.

WARNING! This appliance is not intended for use by persons (including children) with reduced physical, sensory or mental capabilities, or lack of experience and knowledge, unless they have been given supervision or instruction concerning use of the appliance by a person responsible for their safety. Children should be supervised to ensure that they do not play with the appliance.

ENVIRONMENTAL PROTECTION

This appliance is marked according to the European directive 2002/96/EC on Waste Electrical and Electronic Equipment (WEEE).

By taking care of the proper disposal of this appliance, after its working capacity is depleted, you will help prevent possible negative consequences for the environment and people's health. Such negative consequences may be provoked by improper disposal.



The  symbol on the appliance and enclosed documents, is showing that this appliance should not be treated as household waste. Instead, it should be handed over to a specialized station for recycling of electrical and electronic equipment. Upon its disposal, please kindly observe the local regulations for disposal of waste.

For more detailed information regarding treatment, recovery and recycling of this appliance, please apply to your local municipality, your service for disposal of household waste or the store from where the appliance has been purchased.

TECHNICAL INFORMATION

Water heaters 30 – 200 L. are intended for domestic purposes in households, and can provide hot water from the common water main system simultaneously for a few consumers – kitchen, bathroom and etc.

The main models and modifications are presented on Figures from 1 to 4, and the technical data is presented in details in the following pages.

The water containers of the appliances are properly protected against corrosion by using high quality enameled coating, or are made of high-alloyed chrome-nickel steel. Water tanks with enameled coating are equipped with a built-in anode. This anode is produced by a special alloy, which by wearing pout provides additional protection of the enameled coating.

The heated water should be correspond to the normative documents for domestic water and, in particular the composition of chlorides should be less than 250 mg/l, and the electrical conductivity should be more than 100 $\mu\text{S/cm}$ and less than 2000 $\mu\text{S/cm}$ for the water heaters with enameled water tanks, and less than 600 $\mu\text{S/cm}$ for the water heaters with chrome-nickel steel water tanks.

The outer casing of the appliances is made of epoxy-polymer coverage, and the heat insulation is made of polyurethane foam.

The modifications of the water heaters are marked with the following letters and numbers:

- The base model is marked only with a number – a water heater with an enameled water container for vertical installation.

Fig. 2 Water heaters 72265XT and 72268XT – 80 L., 72270XT – 100 L. and 72266XT – 120 L.

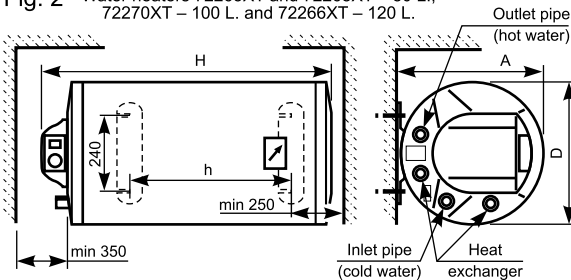

Fig. 3 Water heaters 72267X – 50 L. and 72268X – 80 L.

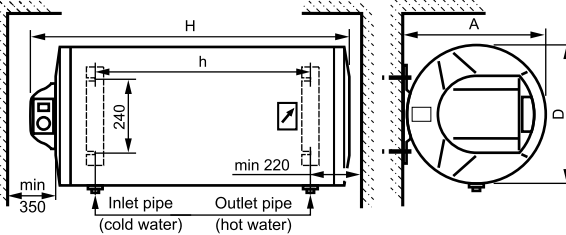
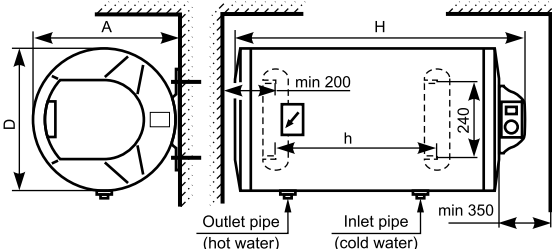
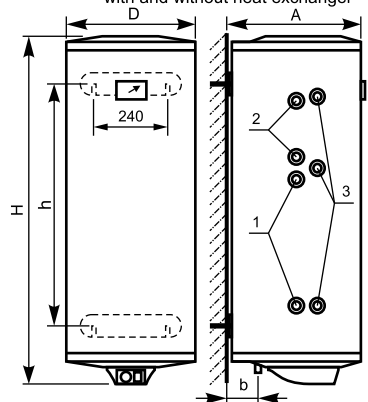

Fig. 4 Water heaters 72265X, 72270X and 72266X – 80, 100 and 120 L.



- „A“ - a built-in indicator for operation of anti-corrosive protection in the enameled water tank and wearing out of the anode.
- „H“ - the water container of the appliance is made of chrome-nickel steel alloy.
- „T“ or „S“ - the water container is equipped with a built-in heat exchanger for water heating up from an alternative heat source (local water heating, solar collector and any other similar sources).

Fig. 1 Vertical water heaters with and without heat exchanger



- 1 and 2 – heat exchangers
- 3 – pockets for additional thermostats (available in some water heaters with heat exchangers)

Models	72269	72267	72265	72268	72270	72266	72280M	72280	72281	72267X	72265X	72270X	72266X
Parameters													
Rated capacity [l]	30	50	80	80	100	120	150	150	200	50	80	100	120
Rated voltage [V]	230 V~												
Rated power [W]	1500 2000	1500 2000	1500 2000 3000	1500 2000 3000	1500 2000 3000	1500 2000 3000	2000 3000	2000 3000	2000 3000	2000	2000 3000	2000 3000	2000 3000
Rated pressure [MPa]	0.8												
Time for heating with electricity from 12 °C up to 65 °C [h]	1.25 0.94	2.09 1.57	3.35 2.51 1.67	3.35 2.51 1.67	4.2 3.15 2.1	5.03 3.77 2.51	5.02 3.14	5.02 3.14	6.7 4.19	1.57	2.51 1.67	3.15 2.1	3.77 2.51
MIX 37 °C upon electrical heating [l]	82	136	218	218	265	326	378	378	494	136	218	265	326
Surface of the heat exchanger [m ²]	-	-	-	-	-	-	-	-	-	-	-	-	-
Overall dimensions [mm]	D	385	385	460	385	460	460	460	586	586	385	460	460
	H	530	740	800	1040	970	1140	1395	990	1230	740	800	970
	A	395	395	470	395	470	470	470	596	596	395	470	470
	b	80	80	92	80	92	92	92	105	105	-	-	-
	h	-	-	-	-	-	-	1003	560	780	405	412	587

The marking “S” stands for a heat exchanger with increased surface, located at the bottom part of the water tank. The water heaters with capacity 80, 120 and 150 L. with two heat exchangers are marked with “S2”.

- „X“ - the water heater can be installed only in horizontal position.
- „R“ - the outlets of the heat exchanger and/or the cold/hot water outlets (on some of the horizontal water heaters) are located on the right side of the wall installed appliance.
- „L“ - in some modifications of the horizontal water heaters the inlet and outlet pipes are located on the left side of the wall installed appliance.
- „D“ - Each water heater from this type is equipped with 2 heating elements, located into special tubes on the flange of the water container. This feature improves the safety of the appliance and increases the corrosion resistance, as well as reduces the sedimentation of limestone. Electrical power of these water heaters is 1600 W for 30 and 50 l, and up to 2400 W for others.

WATER HEATERS FOR VERTICAL INSTALLATION

The water heaters from this type are intended for installation only in vertical position, with inlet and outlet pipes located downwards (Fig. 1).

WATER HEATERS FOR HORIZONTAL INSTALLATION

The water heaters from this type are intended for installation only in horizontal position, according the relative corresponding to their model number, diagram (Fig. 2, 3 and 4). Upon definition of the location place for fixing the device on the wall of the premises, the distance between the cover with the electrical part of the appliance and the adjacent wall should be observed. The horizontal water heaters with capacity 150 and 200 L. are equipped with special brackets for their fixing on the wall of the premises. The relative installation is explained in details in the next section of the present manual.

WATER HEATERS WITH HEAT EXCHANGER

The water heaters of this model secure an energy efficient operation, due to the built-in heat

72280XB	72281XB	72268T 72268S2	72270T	72266T 72266S2	72280MS 72280MS2	72280T 72280S	72281T 72281S	72265XT	72268XT	72266XT	72280XBS	72281XBS
150	200	80	100	120	150	150	200	80	80	120	150	200
230 V~												
2000 3000	2000 3000	2000 3000	2000 3000	2000 3000	2000 3000	2000 3000	2000 3000	2000 3000	2000 3000	2000 3000	3000	3000
0.8												
5.02 3.14	6.7 4.19	2.51 1.67	3.15 2.1	3.77 2.51	5.02 3.14	5.02 3.14	6.7 4.19	2.51 1.67	2.51 1.67	3.77 2.51	3.14	4.19
378	494	218	265	326	378	378	494	218	218	326	378	494
-	-	0.36 0.49+0.22	0.41	0.53 0.65+0.3	0.89 0.89+0.41	0.59 0.89	0.59 0.89	0.33	0.36	0.56	0.59	0.77
586	586	385	460	460	460	586	586	460	385	460	586	586
990	1230	1040	970	1140	1395	990	1230	800	1040	1140	990	1230
596	596	395	470	470	470	596	596	470	395	470	596	596
105	105	80	92	92	92	105	105	92	80	92	105	105
560	780	-	-	- / 754	1003	560	780	412	720	754	560	780

The values of the parameters in the table are approximate.

exchanger. By the heat exchanger the bigger capacity of water inside the water container can be heated up by using an additional alternative of the electricity energy source, i.e. - local or central heating system, solar collectors and other similar sources. For more efficient heat exchanger, it is recommended the heat carrier to be put into operation by a circulation pump. For a heat carrier may be used water with composition and values of the parameters with deviation within the permissible norms, defined in the regulations concerning the water legislation. The heat carrier must be with temperature, not higher than 85 °C. In its circuit must be installed a control device, which set temperature should not allow activation of the thermal cut-out of the electrical heating element during normal operation.

WARNING! The circulation of the heat carrier through the heat exchanger when water of the water tank has been drained out IS FORBIDDEN!

Connection of the water heater to the additional heat source should be performed only by qualified specialists from companies with the relative activity and in accordance with the prepared by them project.

INSTALLATION OF THE WATER HEATER ON THE WALL OF THE PREMISES

The water heater can be installed only in normal fire safeguarded premises and where temperature can not fall under 0 °C. The availability of a siphon on the installation for waste waters or another system with the same purpose is necessary on the floor of the premises. This has to be done as during normal usage of the water heater, water may happen to drop from the opening of the safety valve. The siphon will facilitate the operations of maintenance, prevention and servicing of the water heater in cases when water needs to be drained out of the water tank.

Dimensions of the appliance, the way of fixing, the location of the elements for the fixing and the tubes, its protection against dripping water, the way of fixing and connection to the water main and electrical installations should be taken into account when choosing the proper place for installation. The protection against dripping water is marked on the production plate with the serial number of the appliance. The appliance should be protected against water dispersion or water pouring over.

Water heater should be installed steadily on the wall of the premises. For this purpose steel bolts (studs), tightly fixed in the wall, with diameter 10-12 mm are used. The fixing elements should be secured against pulling aside the wall – they should be anker or passage bolts (depending on the material of the wall). Installation of the water heater on decorative walls (made of single bricks or of other light materials) is inadmissible.

WARNING! The supporting plates of the horizontal water heaters should be firmly tightened to the wall of the premises, as padding discs should be placed under the heads of the bolts (the nuts of the studs)!

Further requirements for the installation of 150 and 200 L. vertical water heaters are presented in Fig. 5 and 6.

Hanging on supporting wall. The supporting walls are made of reinforced concrete, solid bricks work and are featured with thickness of at least 25 cm.

Fig. 5

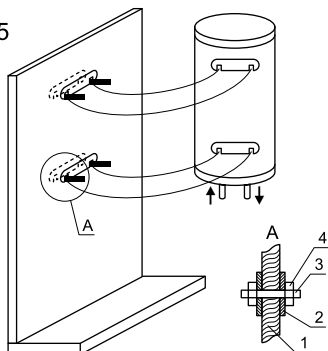

1. Wall
2. Plate
3. Bolt
4. Nut

Hanging on non supporting wall. The non supporting walls are made of non solid bricks and other light materials.

Fig. 6

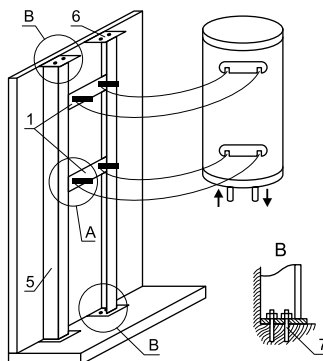

1. Plate 4x60x360
2. Plate of the appliance
3. Bolt (stud) M10
4. Nut ;
5. Column (Elbow 50x50x5)
6. Plate 4x100x100
7. Wall plug for concrete

Note: 1. Positions 1, 5 and 6 are welded.
2. The floor and the ceiling of the premises are made of reinforced concrete.

The horizontal 150 and 200 L. water heaters should be installed only on a reinforced wall with thickness of at least 25 cm, using the brackets, included in the additional set in the cardboard box of the appliance, according to Fig. 7 (see next page). The stand is fixed to the wall using steadily fixed on it studs (anker bolts).

WARNING! Non observance of the requirements for fixing the water heater on the wall may cause damages of the appliance, damages on other appliances and the premises, where the device is located, as well as corrosion of the casing or even more serious failures and damages. In such cases, the eventual damages are not a subject to warranty obligations of the manufacturer and the seller, and will be born by the party which has not observed the present manual.

Installation of the water heater on the wall of the premises should be performed only by qualified persons!

CONNECTION OF THE WATER HEATER TO THE WATER SUPPLY MAIN

Upon connection of the water heater to the pipes for hot and cold water of the water supply main, the arrows and indication rings around the outlets of the water heater should be observed. These are with threading 1/2". With an arrow towards the pipe and a blue color is marked the pipe for cold water (the inlet pipe). With an arrow starting from the pipe and a red

Fig. 7

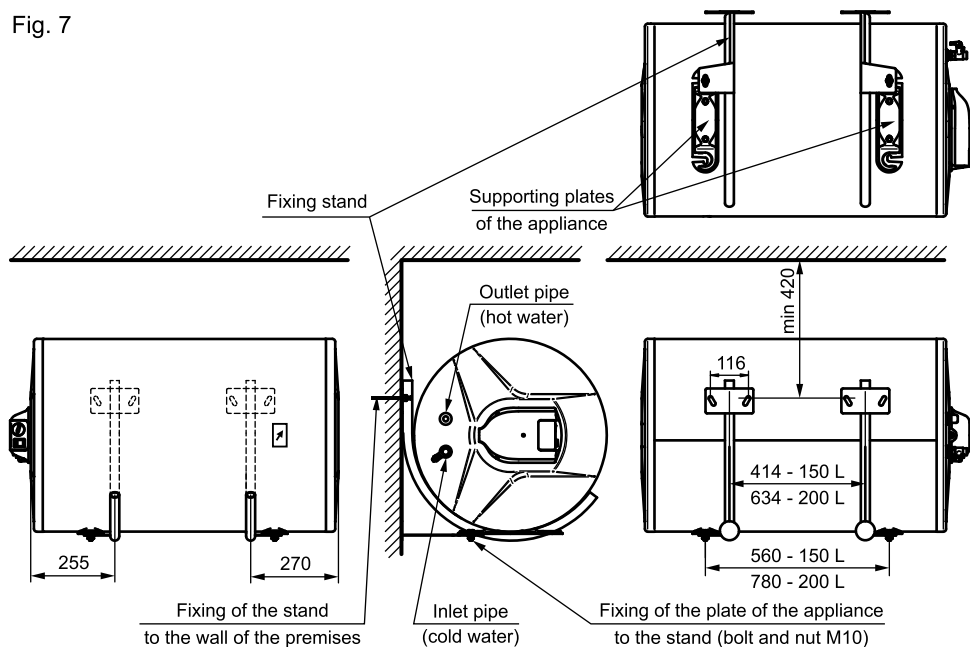

color is marked the pipe for hot water (the outlet pipe). The diagram for connection of the water heater is presented on below Fig. 8.

Fig. 8

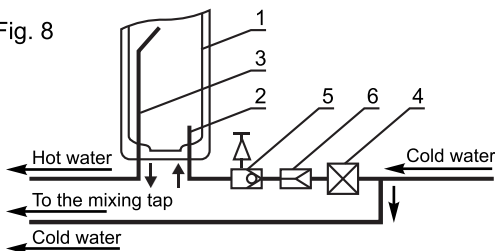

- 1 – Water container
- 2 – Inlet pipe
- 3 – Outlet pipe
- 4 – Braking valve (by request)
- 5 – Combined valve
- 6 – Reducing valve (upon necessity – if pressure of the water supply main is more than 0,6 MPa)

The combined safety reverse valve, which is a part of the complete set of the water heater, is installed by the manufacturer on the pipe for cold water.

Exceptions from the above mentioned are the water heaters for horizontal installation models 72269X - 50 L., 72265X - 80 L., 72270X - 100 L., 72266X - 120 L. and their relative modifications, where the pipes for cold and hot water pass through the cylinder of the casing. In these models the COMBINED VALVE is placed in a bag, fixed on the packing of the appliance and should be OBLIGATORY INSTALLED on the pipe for cold water, observing the arrows on its body, indicating the direction of the passing through it water.

WARNING! It is FORBIDDEN to install any kind of shut-off fittings between the combined valve and the water heater! It is absolutely forbidden to obstruct the lateral opening of the combined valve and/or to block its lever!

If necessary, a system for leading away water, eventually dropped from the lateral opening of the combined valve may be constructed. The water leading pipe should have a permanent downward slope, it should be placed in premises, protected against freezing and its outlets should be permanently connected to the atmosphere.

Once the water heater is connected to the water supply main, its water container should be filled up with water. This is performed in the following order: open completely the turn-cock for hot water of the most distant mixing tap; open the braking valve on pos. 4 from Fig. 8; wait until a thick and powerful stream of water runs out of the mixing tap; close the turn-cock for hot water of the mixing tap; lift the lever of the combined valve and wait for about 30-60 seconds until a thick and powerful stream of water runs out from the lateral opening of the valve; take off the lever of the combined valve.

WARNING! If no water is coming out of the opening of the combined valve, or the stream is weak (in case of normal water-main pressure), this should be considered as a malfunction. This is showing that impurities from the water main or caused by water-main connections have obstructed the safety valve of the combined valve.

IT IS FORBIDDEN to proceed with further connection of the appliance before eliminating the reason for malfunction!

WARNING! Non-observance of the requirements for connection to the water-main system may cause partial filling up with water of the water container and malfunction of the heating element. When the combined valve is not installed at all or it has been improperly installed this may even cause destruction of the water tank. The sequences are not within the scope of the warranty obligations of the manufacturer and the seller, and should be considered for the account of the party, which has not observed the requirements of the present manual.

Connection of the water heater to the water-main system should be performed only by qualified persons.

CONNECTION OF THE WATER HEATER TO THE ELECTRIC SUPPLY SYSTEM

WARNING! Do not proceed with connection of the water heater to electric supply system before you make sure the water container is filled up with water! Please CHECK!

The water heater is with a level of protection against damages from electric current – Class I. Connection of the water heater to the electric supply system is performed through a separate current circuit filled with a three core insulated cable with a section of each core 2,5 mm² (line, neutral and earthing). If the built-in the wall cable is a two core, a qualified person should lead an additional earthing conductor, which should not be cut-off and/or connected on its way from the electric panel up to the water heater. Otherwise the appliance will not be properly earthing connected, which will reduce its safety. In the line circuit, it is obligatory to have an installed electrical safety fuse 10 A if power of the water heater is 2 kW and a safety fuse of 16 A if power of the water heater is 3 kW.

The connection of the conductors of the supply cable to the terminals of the appliance is performed only after a careful disassembly of the plastic cover so that the electric conductors in the appliance do not get disunited. In compliance with the general electric diagram, sticked on the cover, the line core of the supply cord is connected with the terminal marked L (or A1 depending on the modification). The neutral core is connected with the terminal marked N (or B1), and the earthing core is connected with the earthing terminal (screw or bolt), marked with the sign for protective earthing (⊕). The supply cable should be secured against displacement, using a cable-tightening bracket, located right net the opening for the cable in the plastic cover. After connection and fixing of the supply cables is performed, the plastic cover should be placed back and fixed with its screws. During this operation attention should be paid on the loose position of the electric cables, the capillary tube of the thermal cut off and thermal regulator.

WARNING! IT IS OBLIGATORY to incorporate (in accordance with the wiring rules) in the fixed wiring intended for the water heater such a device that ensures complete disconnection of all poles in case of overvoltage category III. The wires of the electric circuit between the device and the incoming electrical terminals of the water heater should not be

interrupted by another circuit breaker or safety fuse. If the water heater is installed in the bathing premise, that device must be mounted outside.

After connection of the water heater to electric supply system, it is necessary to check its functionality.

WARNING! Non-observance of the requirements for connection to the electrical installation may happen to reduce the safety of the appliance. And an appliance with a reduced safety is not allowed to be used. The consequences are not within the warranty obligations of the manufacturer and the seller, and will be taken on the account of the user who has failed to observe the requirements of the present manual.

Connection of the water heater to the electrical installation and the relative subsequent check up for its proper functioning should be performed only by a qualified person!

OPERATION WITH THE WATER HEATER

The water heater is turned on in an automatic regime by switching over the lighting key, pushing its end marked with "I". Using the wheel you may set the desired temperature of water. Light on the key, when it is turned on, is an indication for heating element turned on and water is being heated up, and light off – an indication that water has reached the set temperature and heating element is off.

At water heaters marked with „D” letter each key of the two-keys lighting switch, located on the control panel, turns on/off one of the heating elements. This provides the possibility to operate with the half or the complete electrical power of the heating elements, depending on the specific needs and desired period of time for heating of water.

The built-in the appliance thermostat is featured with “Antifreeze” function. When the wheel of the thermostat is at maximum left position, at the beginning of the scale, the heating element of the appliance will turn on upon environmental temperature around 8-10°C, and will turn off around 12-15 °C. In such a way the water in the water tank will be protected against freezing upon temperature drop in the premises. **ATTENTION!** This function will not protect water in the water supply main in the premises against freezing!

The installed on the appliance temperature indicator is illustrating the process of water heating up and is showing an approximate temperature.

WARNING! Do not turn the appliance on if a possibility of water frozen in the water tank exists! This will cause damage of the heating element and the water tank!

WARNING! This appliance is not meant for usage by persons (including children) with limited physical, sensory or mental abilities or with insufficient experience and knowledge, except in cases when they are observed or instructed regarding the operation with the appliance by a person, responsible for their safety. Children should be watched over for not playing with the appliance.

A special valve has been built in the combined valve, preventing the extended during the heating process water from dripping out of the lateral opening of the valve during normal operation of the water heater. Instead it leads the water to the cold water supply main. This quantity of water is minimum and with low temperature. Upon normal exploitation of the water heater and upon availability of an additional reverse valve, water may happen to drip out of the lateral opening of the valve. This should not be considered as a malfunction and the opening of the valve should not be obstructed in any way, as it will cause damage of the water tank. Upon water supply stop, the built-in reverse valve prevents the contained in the water tank quantity of water from going back to the water supply system for cold water.

ANTI-CORROSION PROTECTION, MAINTENANCE AND SERVICE

Water heater with enameled water container.

Each water heater with enameled water container is equipped with an additional anti-corrosion protection. It consists of an anode protector (anode), made of a special alloy and operating only if the water tank is filled up with water. Its medium exploitation duration is 3 years. After the expiry of this term, a specialist from the company service centers should perform a check up of the anode status. Upon a registered necessity, the anode should be replaced with a new one. The observance of this term and the replacement in due time is an important condition for extending the efficient protection of the water container against corrosion.

Water heater with enameled water container and anode tester.

The availability of this information device is an important feature for the exploitation of the water heater. The tester consists of an arrow system with a scale and a change-over switch (button). The scale is with two sectors – a red and a green one. In normal working condition of the water heater, the arrow of the tester is located in the red sector – the tester is turned on and the anode is properly operating. The check-up of the anode efficiency is performed when water is completely heated up (thermostat cut off - lighting key turned off) by pushing the button of the tester for a few seconds. The arrow will deviate in the green sector direction of the scale. The value of the deviation is strongly influenced by the parameters of water and its temperature, as the limit between the two sectors corresponds to the average values of water. Criteria for the efficiency of the anode is the deviation of the arrow. When by pushing the button of the tester, the arrow does not deviate or remains in the beginning of the red sector, you should contact the specialists from the closest, authorized by the manufacturer, service center – please refer to the attached list of companies. They will check up the anti corrosion protection and, if necessary, will perform a repair. The replacement of the anode protector in due time is a precondition for life extension of the enameled water tank.



Water heater with a water tank made of high alloyed chrome-nickel steel. The corrosion protection and the guaranteed long exploitation period are secured by properly chosen steel, proper construction and technology of the production process of the water tank.

For reliable operation of the water heaters in regions with high content of limestone in the water, we recommend the water heater to be cleaned up from limestone once per year. The deposition over the enamel layer should not be removed, but only wiped with a dry cotton cloth without using any hard devices. This is not a subject to warranty service and should be performed only by a qualified and competent specialist.

During the operation of the water heater, it is necessary to perform minimal, but very important preventive actions. These are described in details in p. 7, 9 and 10 from section „Important rules“ of the present manual.

IMPORTANT RULES

1. The water heater is meant for domestic purposes in the household. It is used for heating the water from the common water main system. Its composition and parameters should be within the scope of the defined by the relative regulations regarding the legislation for domestic water as the composition of chlorides is less than 250 mg/l, and the electrical conductivity is more than 100 $\mu\text{S}/\text{cm}$ but less than 2000 $\mu\text{S}/\text{cm}$ for water heaters with enameled water tanks; and less than 600 $\mu\text{S}/\text{cm}$ for water heaters with water tanks made of chrome-nickel steel.
2. Water heater is installed and used only in fire-safeguarded places and in conditions, corresponding to its level of protection against water penetration. Otherwise, a defect of the appliance will be caused due to non-observance of the present manual for installation and operation. This defect will not be within the scope of the warranty obligations of the manufacturer or the seller.
3. **WARNING!** This appliance is not intended for use by persons (including children) with reduced physical, sensory or mental capabilities, or lack of experience and knowledge, unless they have been given supervision or instruction concerning use of the appliance by a person responsible for their safety. Children should be supervised to ensure that they do

- not play with the appliance.
4. Upon connection of the water heater to the electric-supply system, the proper connection to the neutral and protective earthing conductor of the cable from the electrical installation of the premises is **OBLIGATORY**. Non-observance of this requirement will deteriorate the safety of the appliance, and an appliance with a reduced safety is not allowed to be used.
 5. Connection of the water heater to water-main system and electric-supply system and functionality check up should be performed only by an authorized person.
 6. Connection of water heater and functionality check up are not warranty obligations of the manufacturer or seller, and should not be considered as a subject to warranty service.
 7. **WARNING!** In cases of possible drop of temperature under 0°C in the premises where the water heater has been installed, draining of water from the water tank is obligatory – please refer to p. 9.
 8. **WARNING!** In order to secure safe and faultless operation of the water heater, the combined valve periodically needs to be blown through. This is performed by lifting its lever until a thick and powerful stream of water starts flowing out of the lateral valve opening for about 30-60 seconds. This operation is obligatory performed only after water heater has been connected to the water-main system and water tank has been filled up with water. It should be repeated once in each 14 days of operation, as well as after each water supply stop. In case that water tank is full and there is no outflow of water or the stream is very weak, this is an indication that the combined valve is out of order or the valve is obstructed with impurities from the water main. It is strictly forbidden to operate with a water heater with a combined valve which is out of order. Please turn off immediately the water heater from the electric supply and contact the closest service center or, authorized by the manufacturer or seller. Otherwise, you may cause a defect in the water tank and probably other damages of the premises.
 9. The safety valve, upon necessity, is also used for draining of water out of the water tank. This is performed in the following order:
 - Turn off the water heater from the electrical network using the additional device and for bigger safety turn off the electrical fuse in the phase circuit to the water heater.
 - Stop the access of cold water towards the appliance – close the cock as per pos. 4 of Fig. 8.
 - Open the cock for hot water of the mixing tap or disunite the connection of hot water of outlet tube of the water heater.
 - Lift up the lever of the combined valve and wait until water stops dripping out of the valve opening.

These actions do not secure complete draining of water out of the water tank. It should be performed only by a qualified and competent specialist, as it relates to disconnection of the electrical scheme of the appliance and removal of the water heater's flange.

WARNING! IT IS STRICTLY FORBIDDEN TO TURN ON THE ELECTRIC SUPPLY TO THE WATER HEATER WHILE THE WATER CONTAINED IN THE WATER TANK IS DRAINED OUT PARTIALLY OR COMPLETELY! Before turning on the appliance in working regime do not forget to fill up the water tank with water again – please refer to Section "Connection of the water heater to the water-main system".

WARNING! The circulation of the heat carrier through the heat exchanger when water tank has been drained out is **FORBIDDEN**.

WARNING! During water draining out of the water tank, take all necessary measures against damages caused by drained away water.

10. The rules for preventive maintenance, replacement of anode and elimination of limestone, should be observed also after expiry of the warranty term of the appliance.

WARRANTY AND WARRANTY CONDITIONS

Warranty term is determined by seller and is in force only for the territory of the country.

Warranty is valid only if the appliance:

- is installed according to the requirements for installation and operation.
- Is used only as per designed purpose and in accordance with the installation and operation manual.

Warranty consists of free of charge repair of all factory defects, which may arise during the warranty term. Repair is performed by service specialists, authorized by seller.

Warranty is not valid for defects, caused by:

- Improper transportation
- Improper storage
- Improper usage
- Parameters of water, different from the admissible according to the European norms for quality of drinking water, and particularly if the composition of chlorides is more than 250 mg/L, and the electrical conductivity is less than 100 $\mu\text{S/cm}$ and more than 2000 $\mu\text{S/cm}$ for water heaters with enameled water tanks; and more than 600 $\mu\text{S/cm}$ for water heaters with water tanks made of chrome-nickel steel.
- Applying higher than the nominal appliance's voltage in the electrical network.
- Deformation of the water tank due to freezing of water.
- Elemental perils, disasters and other force majeure circumstances.
- Non observance of the installation and operation manual.
- In cases, when a non authorized person has tried to repair any kind of a defect.

In the above cases the defect will be repaired against relative payment.

OBSERVANCE OF THE PRESENT MANUAL REQUIREMENTS IS A PRECONDITION FOR A SAFETY OPERATION OF THE PURCHASED BY YOU PRODUCT AND IS ONE OF THE WARRANTY CONDITIONS.

ANY ALTERATIONS OR READJUSTMENT IN THE CONSTRUCTION OF THE PRODUCT, MADE BY THE CONSUMER OR UNAUTHORIZED PERSONS, ARE FORBIDDEN. IF SUCH ACTIONS HAVE BEEN REPORTED THIS WILL AUTOMATICALLY CAUSE TERMINATION OF WARRANTY OBLIGATIONS BY THE MANUFACTURER OR SELLER.

IN CASE OF NECESSITY, PLEASE CONTACT THE AUTHORIZED BY THE MANUFACTURER SERVICE CENTERS, MENTIONED IN THE ENCLOSED LIST.

MANUFACTURER RESERVES ITS RIGHT TO PERFORM CONSTRUCTION CHANGES, WHICH DO NOT DETERIORATE THE PRODUCT SAFETY, WITHOUT NOTIFICATION.