



# HIGH-EFFICIENCY REGULATED FLANGED PUMP NMT SMART 80 F

SMART

## PERFORMANCE

High efficiency ECM motor series pumps with canned motor and permanent magnets. Variable and constant pressure control through display. For use in water system according to requirements of VDI 2035.

## APPLICATIONS

All heating systems, air condition systems, closed loop cooling systems and industrial circulatory systems.

## OPERATION

- Auto mode (default)
- Proportional pressure control
- Constant pressure control
- Constant speed
- Night mode

## PRODUCT DESCRIPTION

- High efficiency ECM technology
- Energy savings
- LED Display for control
- Easy handling and installation
- Plug & Play
- Robust and compact construction for long life
- Automatic venting
- Low noise operation
- Possibility of housing with cataphoretic
- Possibility of NMT communication module

Pump component	Material
Housing	Cast iron
Impeller	PES
Shaft	Stainless steel
Bearings	Graphite
Ventricular wall	Stainless steel
Rotor can	Stainless steel

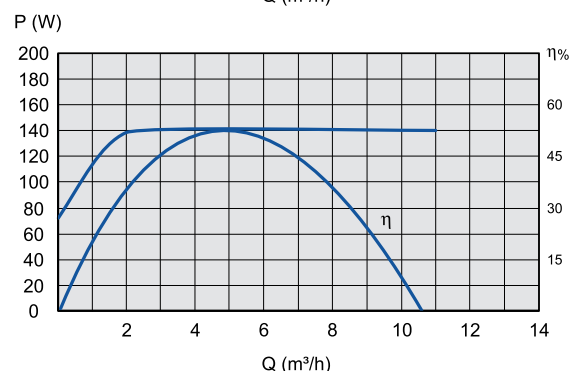
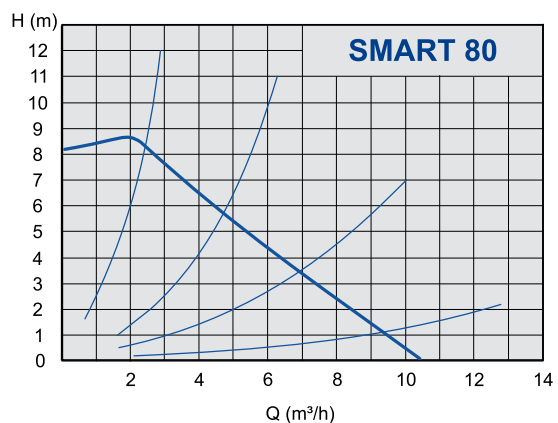

NMT	DN	Fitting length	N. Pressure	Weight	Code	Euro
SMART 32-80 F	32	220 mm	PN 10	7,4 kg	979523486	596,00 €
SMART 40-80 F	40	220 mm	PN 10	8,5 kg	979523487	652,00 €
SMART C 32-80 F	32	220 mm	PN 10	7,6 kg	979523497	739,00 €
SMART C 40-80 F	40	220 mm	PN 10	8,7 kg	979523498	795,00 €

Dimensions	h	DN	b1	l	a
SMART 32-80 F	220	32	117	190	70
SMART 40-80 F	220	40	117	190	75
SMART C 32-80 F	220	32	117	222	70
SMART C 40-80 F	220	40	117	222	75

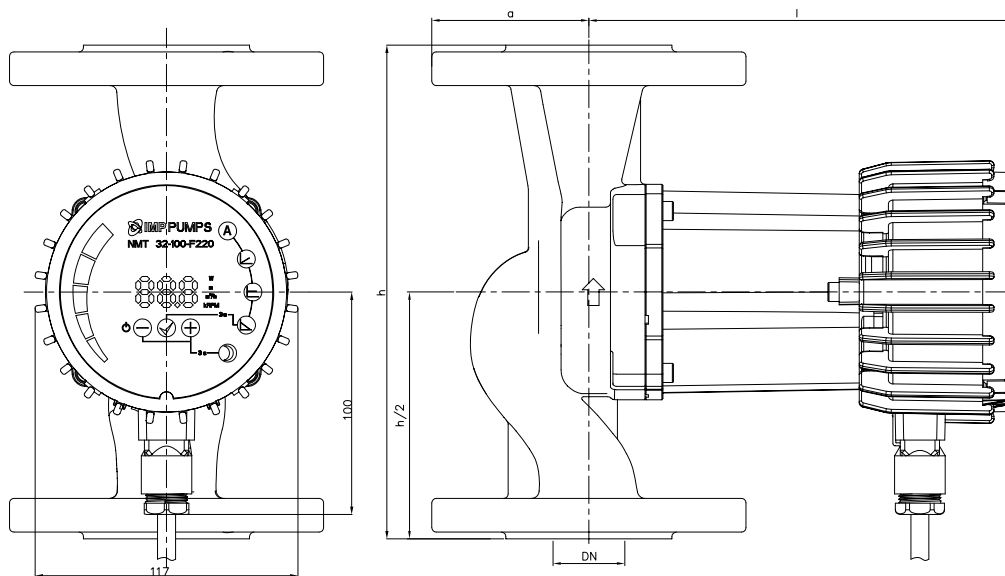

## TECHNICAL DATA

Flow Q up to 10 m<sup>3</sup>/h  
 Pressure H up to 8 m  
 Power 7 - 60 Watt  
 Nominal pressure 10 bar

### Permissible mediums

- Water, mixed with glycol, parameters must be checked in the mixture of water with over 20% of glycol
- Pure non-explosive liquid media free from mineral oils and without solid particles

### Permissible temperature range

- Medium temperature from +2 °C to +110 °C with max. surroundings temperature up to +40 °C

### Minimum inlet pressure

0,05 bar < 75 °C Temperature of medium  
 0,28 bar < 90 °C Temperature of medium

### Electrical connection

Voltage 1 ~ 230 V, 50/60 Hz

### Motor/Electronics

- Motor with permanent magnets
- The energy index EEI ≤ 0,21
- Built-in motor protection
- 3 control modes (proportional head, constant head, constant speed)
- Degree of protection: IP 44
- Insulation class F