

Expansion tanks

<i>ER series</i>	4
<i>ERE-ERCE series</i>	6
<i>ERL series</i>	8
<i>ERP series</i>	10
<i>D series</i>	14
<i>Sizing of an expansion tank with a fixed bladder –technical data</i>	16
<i>ERL-DAC series</i>	18
<i>Sizing of an auto-pressurised expansion tank -technical data</i>	21
<i>Some examples of installation</i>	24
<i>(flyleaf of the back cover) Universal diagram</i>	





**COMPANY
WITH QUALITY SYSTEM
CERTIFIED BY DNV**
ISO 9002

E x p a n s i o n t a n k s

Expansion tanks are devices designed to absorb the volume change of water or some other liquids, thus allowing the correct operation of a heating plant during all its operative phases.

Elbi produces closed expansion tanks composed by a tank in sheet steel and a bladder in synthetic material which separates the heating circuit from a chamber previously charged with air.

Expansion tanks with a bladder, which are available from 5 to 5.000 litres, are constructed by using quality sheet steels according to UNI-EN regulations and welded according to some strict qualitative standards; they are produced on automated lines, welded with procedures and approved weld materials, equipped with bladders in special rubber used against heat and ageing which are resistant up to 110° C (all of them are produced by ELBI); they are previously charged at a pressure of 0.5 – 1.0 – 1.5 bars according to the static height of the water column.

Once the construction has been completed, all the models are subjected to a hydraulic test with a pressure of 1.5 times higher than the designed one.

There are also some versions constructed according to the most important European regulations in force.

E l b i b l a d d e r s

Elbi produces all the bladders which mounts on its own equipment, as for the production it makes exclusive use of modern injection presses, the most advanced ones in this sector.

Dies designed by the Elbi technical department ensure the complete compatibility with tanks. All the bladders are tested by the company's quality control service at the end of the production run. Bladders which are used in the ERL series are constructed by applying an exclusive process which allows to obtain the exact dimensions corresponding to the tank's actual volume, thus eliminating every kind of mechanical stress during the operation.

Their mixing is the result of some studies and researches carried out directly by the Elbi technical department.

ERE-ERCE series

35 to 500 litres



The available models from 35 to 500 litres are designed to be installed in the different types of plant.

Besides, they are available in special versions, constructed according to the most important international regulations: CE, TÜV, WRc, UDT, CZ, etc.

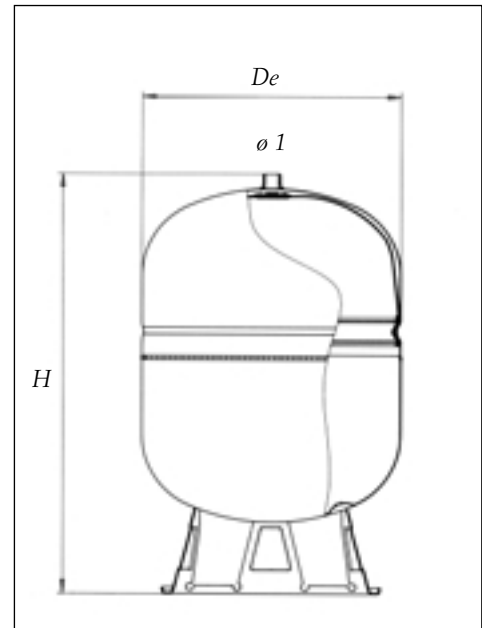

Characteristics:

- (Designed working temperature: $-10^{\circ}\div 110^{\circ}\text{C}$)
- Sturdy structure in high-quality steel, designed to endure for a long time.
- Painting with long life epoxy powders.
- Bladders in special rubber with those characteristics which ensure better performances and a longer life.
- CE certified

Model	Capacity litres	Maximum working pressure bar	Precharge pressure bar	De	H mm	Ø1	Packaging mm
ERE - ERCE 35*	35	10	1,5	400	390	3/4"	410 x 410 x 410
ERE - ERCE 50*	50	10	1,5	400	498	1"	410 x 410 x 535
ERE - ERCE 80	80	10	1,5	400	838	1"	410 x 410 x 860
ERE - ERCE 100	100	10	1,5	500	792	1"	510 x 510 x 830
ERE - ERCE 150	150	10	1,5	500	1.022	1"	510 x 510 x 1040
ERE - ERCE 200	200	10	1,5	600	1.090	1"	610 x 610 x 1100
ERE - ERCE 250	250	10	1,5	650	1.186	1"	660 x 660 x 1210
ERE - ERCE 300	300	10	1,5	650	1.264	1"	660 x 660 x 1290
ERE - ERCE 500	500	10	1,5	775	1.423	1" 1/4	785 x 785 x 1440

*Standard without base, upon request with teet.

Selection of the expansion tank

The table simplifies the choice of the ELBI expansion tank to be installed in hot water systems. The selection of the tank can be effectuated starting from the system's total capacity or from the plant's power, taking into consideration an average content of 12 litres per 1000 Kcal/h of power.

pressure Model	Precharge maximum bar	Plant's height working pressure bar	Plant acceptable m	Tank's absorption volume litres	Tank's n capacity %	Temperature difference at = 90° C Δ coefficient of expansion 0.035		
						Total water content in the plant litres	Heat-generator's power Kcal/h	kW
ERE/CE 35	1	3	10	17,6	50	503	41.900	48.72093
	1,5		15	13,1	37	374	31.200	36.27907
	2		20	8,8	25	251	20.900	24.30233
ERE/CE 50	1	3	10	25	50	714	59.500	69.18605
	1,5		15	18,8	38	537	71.400	52.03488
	2		20	12,5	25	357	29.750	34.59302
ERE/CE 80	1	3	10	40	50	1.143	95.250	110.7558
	1,5		15	30	38	857	71.400	83.02326
	2		20	20	25	571	47.600	55.34884
ERE/CE 100	1	5	10	50	50	1.428	119.000	138.3721
	1,5		15	38	38	1.086	90.500	105.2326
	2		20	25	25	714	59.500	69.18605
ERE/CE 150	1	5	10	100	67	2.857	238.000	276.7442
	1,5		15	87	58	2.486	207.000	240.6977
	2		20	75	50	2.143	178.600	207.6744
ERE/CE 200	1	5	10	133	67	3.800	317.000	368.6047
	1,5		15	116	58	3.314	276.000	320.9302
	2		20	100	50	2.857	238.000	276.7442
	2,5		25	83	42	2.371	197.600	229.7674
	3		30	66	33	1.886	157.200	182.7907
ERE/CE 250	1	5	10	178	71	5.086	423.800	492.7907
	1,5		15	160	64	4.571	380.900	442.907
	2		20	143	57	4.086	340.500	395.9302
	2,5		25	125	50	3.571	297.600	346.0465
ERE/CE 300	3	6	30	107	43	3.057	254.800	296.2791
	1		10	214	71	6.114	509.500	592.4419
	1,5		15	193	64	5.514	459.500	534.3023
	2		20	171	57	4.886	407.000	473.2558
	2,5		25	150	50	4.286	357.200	415.3488
ERE/CE 500	3	6	30	128	43	3.657	304.800	354.4186
	1,5		15	321	64	9.171	764.300	888.7209
	2		20	285	57	8.143	678.600	789.0698
	2,5		25	250	50	7.143	595.300	692.2093
	3		30	215	43	6.143	512.000	595.3488
	3,5		35	178	36	5.086	427.000	496.5116

